

# Premium Supply

---

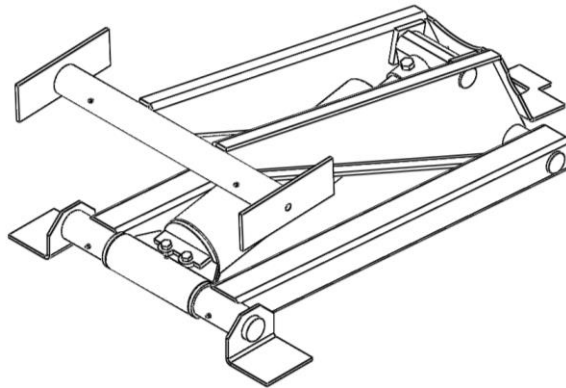

## ***Power Hoist***

Models

PH310, PH416, PH516, PH520, PH620, PH625, PH630  
and Trailer Jack with Hoist

Operator's Manual and Installation Instructions

## **Premium Supply**

2038 West Interstate 30

Greenville, Texas

866-934-0777

Proud members of:



and



July 25, 2014

## Table of Contents

Introduction .....	3
Important Information .....	3
Warranty .....	4
Safety First.....	5
Safety Sign Locations .....	5
Safety Precautions .....	6
Parts Included in Hoist Kit .....	7
Safety Arm Installation and Use .....	8
Large Hinge Installation .....	10
Small Hinge Installation .....	10
Hoist Location on Trailer.....	11
Hoist Mounting Dimensions.....	12
Hoist and Hinge Grease Points .....	13
Dual Acting Hydraulic Power Unit Installation .....	14
Single Acting Hydraulic Power Unit Installation.....	16
Battery Hookup Double Acting HPU.....	18
Battery Hookup Single Acting HPU .....	18
Parts Included in Trailer Jack Kits .....	19
Dual Hydraulic Trailer Jack Installation .....	20
Single Hydraulic Trailer Jack Installation.....	21
Dual Double Acting Trailer Jack and Hoist HPU Connections .....	22
PH310 Hoist Dimensions and Capacity .....	24
PH416 Hoist Dimensions and Capacity .....	26
PH516 Hoist Dimensions and Capacity .....	28
PH520 Hoist Dimensions and Capacity .....	30
PH620 Hoist Dimensions and Capacity .....	32
PH625 Hoist Dimensions and Capacity .....	34
PH630 Hoist Dimensions and Capacity .....	36
Hoist Fully Open Dimensions .....	38

## INTRODUCTION

This manual covers proper hoist installation, hydraulic connection, wiring and service of the Premium Supply hoists listed on the cover. **NOTICE: It is the end users responsibility to determine appropriate support member strength and weld size to properly support the load being lifted. Illustrations are for instructional purposes only.**

Each kit contains an adhesive serial number tag which must be affixed to the hoist in the area shown.

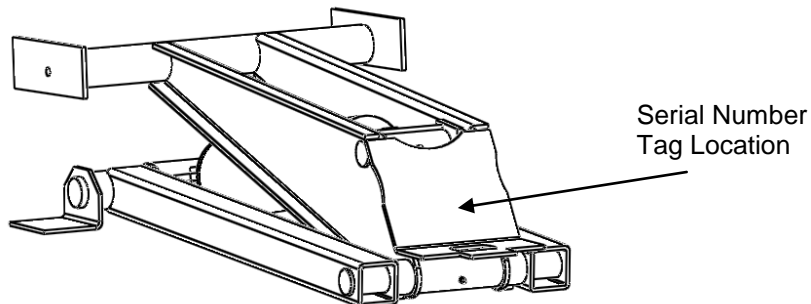

## IMPORTANT INFORMATION

Hoist Model Number:	
Hoist Serial Number:	
Pump Installation and Operation Manual Number:	
In Service Date:	
Dealer:	
Address:	
City, State, Zip:	
Dealer Phone Number:	

## **WARRANTY**

### **Standard Warranty:**

Premium Supply warrants your product to be free from defects in material and workmanship for a period of 36 months from the original date of purchase. If you discover a defect in a product covered by this warranty, we will repair at our option using new or refurbished components, or if repair is not possible, replace the item. This warranty is non-transferable.

### **Warranty Extension:**

Premium Supply warrants for 5 years from the date of purchase any of its kits that have the three products listed below in the circuit and have a hydraulic fluid pre-filtration process in place. The hydraulic fluid must be pre-filtered while being put into the hydraulic pump reservoir, with a FPH cleanliness code of at least (ISO 4406) 15/12. All single acting circuits must be plumbed with a hydraulic hose going to both sides of the cylinder. (Contact Premium Supply for instructions on how to implement these quality control measures).

1. KTI power unit (single or double acting, "with a ground wire connected directly from the battery post to the electric motor of the pump")
2. Bridon Load Control Valve (on the load holding port)
3. SP-2 SolarPulse Solar Panel (mounted per our recommendation)

### **Exclusions:**

This warranty covers defects in manufacturing discovered while using the product as recommended by the manufacturer. The warranty does not cover loss or theft, nor does coverage extend to damage caused by misuse, improper installation, abuse, unauthorized modification, improper storage conditions, or natural disasters. This warranty does not cover parts that are subject to normal wear and tear. Paint, finishes or paint preparation done by the customer are not covered under this warranty, nor is deterioration of the paint and appearance caused by normal wear and tear. This warranty becomes void upon modifications not authorized by Premium Supply.

### **Limits of Liability:**

Should the product fail, your sole recourse is repair or replacement, as described in preceding paragraphs. Premium Supply will not be liable to you or any other party for damages resulting from failure of the product. Damages not covered by this warranty include, but are not limited to, lost profits, lost savings, damage to other equipment, incidental or consequential damages arising from the use or inability to use this product. In no event will Premium Supply be liable for more than the amount of your purchase price, not to exceed the current list price of the product and excluding tax, shipping and handling charges. By using this product, user accepts all terms stated herein.

Premium Supply reserves the right to make improvements to any model or product without notice. This warranty supersedes all previous warranties written or implied.

## SAFETY FIRST

 This symbol is used to call attention to instructions concerning personal safety. Be sure to observe and follow these instructions. Take time to be careful!

A brief description of signal words that are used in this manual follows:

 **DANGER** indicates an imminently hazardous situation which, if not avoided, WILL result in death or serious injury.

 **WARNING** indicates a potentially hazardous situation which, if not avoided, COULD result in death or serious injury and includes hazards that are exposed when guards are removed.

 **CAUTION** indicates a potentially hazardous situation which, if not avoided, MAY result in minor or moderate injury. It is also used to alert against unsafe practices.

## SAFETY SIGN LOCATIONS

Safety signs are included with the hoist kit purchased by you or the trailer manufacturer. Place these signs on both sides of trailer as shown below.

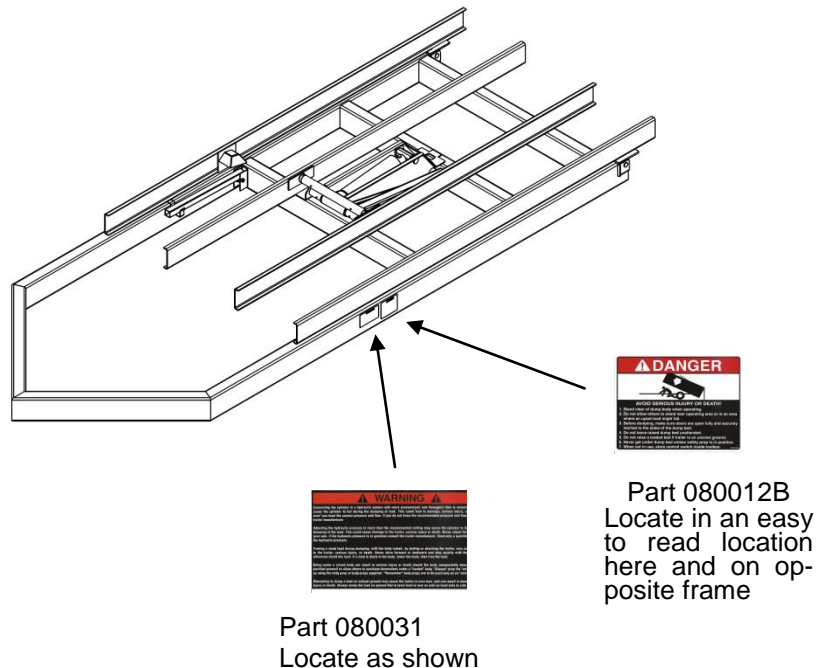

 Read all safety signs on the trailer and in this manual. Keep these signs clean and replace any lost or destroyed signs.

## SAFETY PRECAUTIONS

### **WARNING**

Installing or operating this hoist without first understanding proper installation and operation procedures could lead to serious injury or death. Always read and fully understand all installation and operation manuals before installing or operating this equipment. Contact Premium Supply with any questions.

### **WARNING**

Overloading a trailer could cause vehicle or trailer component damage resulting in injury or death. **NEVER** exceed the gross vehicle weight (GVW) or gross axle weight (GAW) rating of the trailer or your vehicle.

### **WARNING**

Damage to brake lines during manufacturing and installation of the hoist, as well as installing any hardware (bolts, nuts, brackets) in a way that they may rub and damage the brake system, could lead to brake failure. This can cause an accident that could cause injury or death. **ALWAYS** take adequate steps to prevent brake system damage during installation of the hoist, and take precaution to ensure that installed equipment does not interfere with brake system.

### **WARNING**

Malfunctioning equipment could cause property damage, injury or death. **ALWAYS** have faulty equipment repaired before continuing use. Consult the trailer manufacturer if required.

### **WARNING**

Welding, oxy-fuel cutting, or grinding could cause fuel to ignite. This could lead to injury or death. **ALWAYS** take adequate steps to avoid the ignition of fuel from fuel tanks when welding, oxy-fuel cutting, and/or grinding during installation.



### **WARNING**

Heat from the vehicles exhaust system could cause hydraulic component failure. This could lead to a fire that can lead to injury or death. **ALWAYS** install equipment in locations where the exhaust system heat will not damage any components critical to operation.

### **WARNING**

Never attempt to jerk or shock the trailer body with the body raised to remove a stuck load. Jerking or shocking the trailer in this position can cause damage that could result in injury or even death. **NEVER** drive forward or reward and stop quickly to “unstick” the load. If load is stuck, lower trailer body and free load.

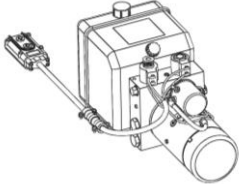
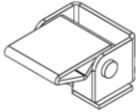
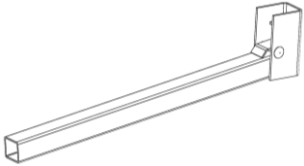
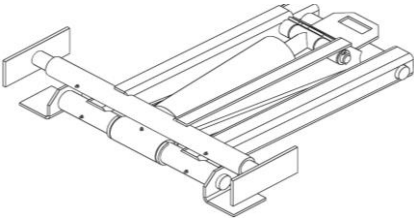
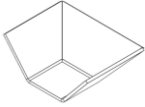
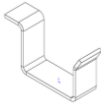
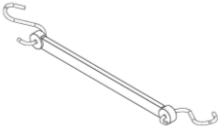
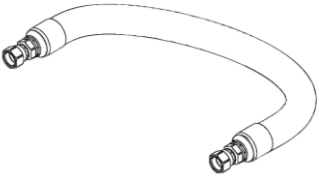
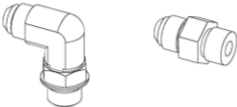
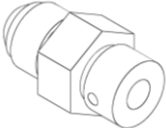
**PARTS INCLUDED IN HOIST KIT**

 <p>Hydraulic Power Unit (HPU)</p>	 <p>Hinge</p>
 <p>Safety Arm</p>	 <p>Hoist Assembly</p>
 <p>Safety Arm Cup</p>	 <p>Safety Arm Storage Arm Bracket</p>
 <p>Rubber Battery Strap</p>	 <p>Hydraulic Hoses Between HPU and Cylinder</p>
 <p>Hydraulic Fittings</p>	 <p>Bridon Load Control</p>
 <p>Battery Cables</p>	 <p>Locking Collars</p>

## SAFETY ARM INSTALLATION AND USE

### **WARNING**

Always support an unloaded body with the safety arm. The safety arm is meant to support the weight of an unloaded body only.

### **WARNING**

Being under a raised body could result in serious injury or death should the body unexpectedly descend. Never position yourself or allow others to position themselves under a loaded body. Always support an unloaded body with the supplied safety arm. NEVER use the safety arm on a loaded body.

#### Safety Arm Use:

- 1 Raise trailer body to sufficient height and shut off hydraulic power to hoist.
- 2 Grasp safety arm and rotate into the up/vertical position.
- 3 Once vertical position is accomplished, push arm down into the support bracket at base of arm.
- 4 **SLOWLY** lower the hoist and body until the cup contacts the vertical facing arm.
- 5 Reverse the above procedure to place arm back in its hanger for transport (be sure to lower hoist to full down position upon placing arm back in hanger).

#### Maximum Unloaded Tilt Body Weight in Pounds Using One Safety Arm

		Trailer tilt body length in feet						
		8	10	12	14	16	18	20
Distance between rear hinge and safety arm in inches	50	3854	3083	2569	2202	1927	1713	1542
	60	4625	3700	3083	2643	2313	2056	1850
	70	5396	4317	3597	3083	2698	2398	2158
	80	6167	4933	4111	3524	3083	2741	2467
	90	6938	5550	4625	3964	3469	3083	2775
	100		6167	5139	4405	3854	3426	3083
	110		6783	5653	4845	4240	3769	3392
	120		7400	6167	5286	4625	4111	3700
	130			6681	5726	5010	4454	4008
	140			7194	6167	5396	4796	4317
	150				6607	5781	5139	4625
	160				7048	6167	5481	4933
	170					6552	5824	5242
	180					6938	6167	5550
	190					7323	6509	5858
	200						6852	6167
210						7194	6475	
220							6783	
230							7092	



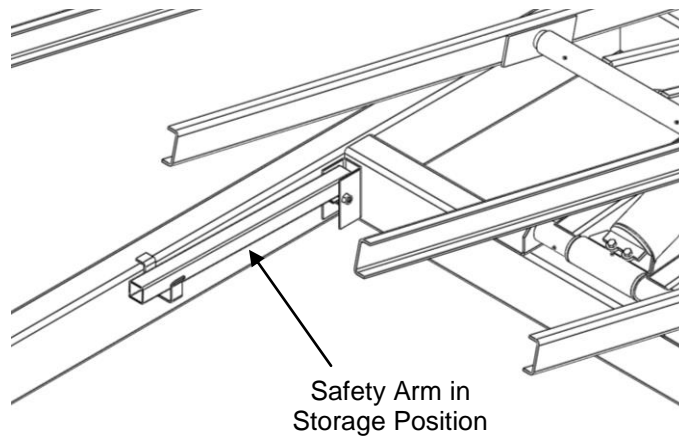
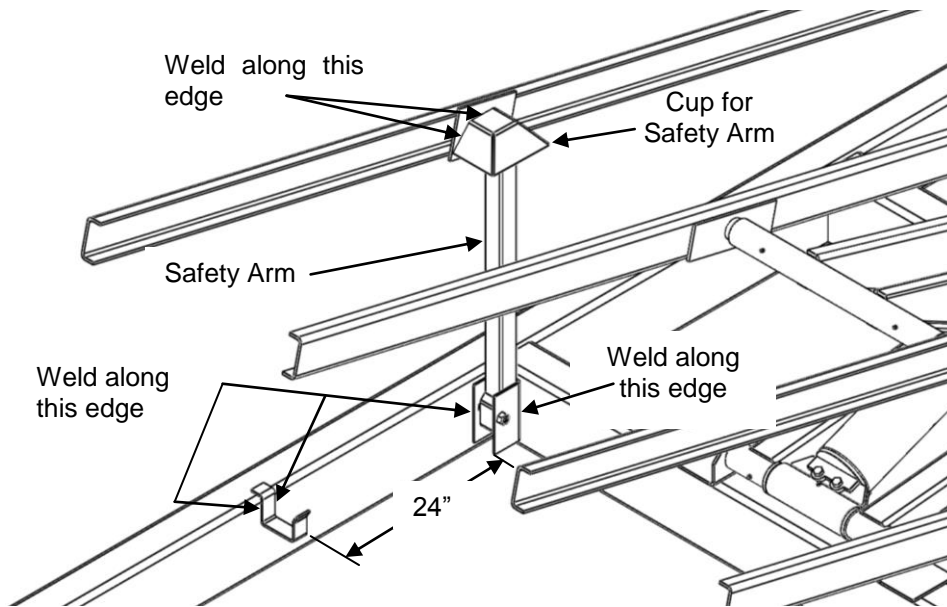

## LARGE HINGE INSTALLATION

For model PH 620, 625, 630 hoists

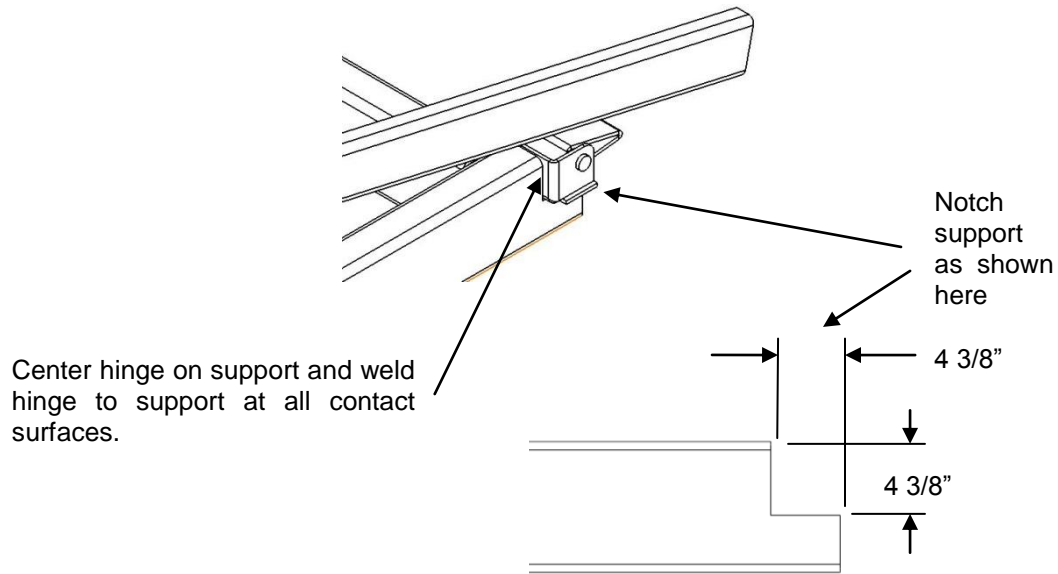

## SMALL HINGE INSTALLATION

For model PH 310, 416, 516, 520 hoists

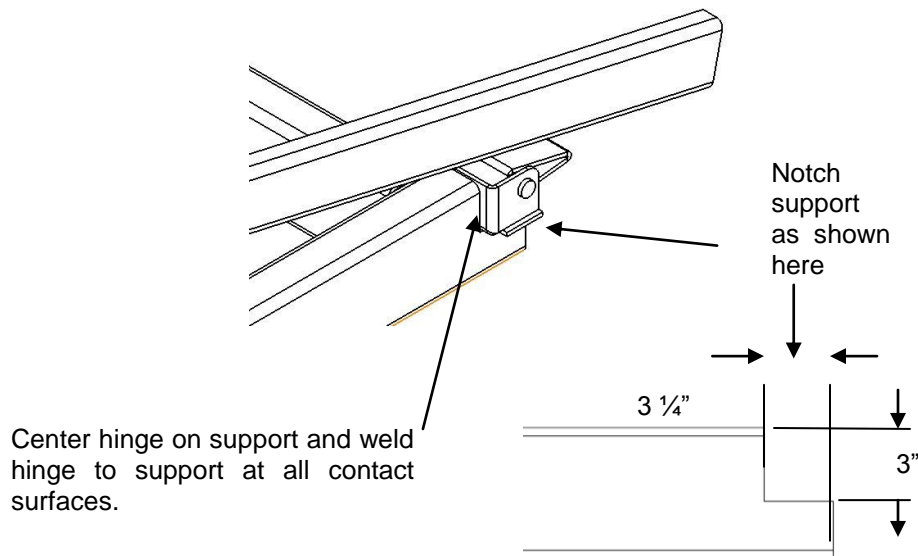

## HOIST LOCATION ON TRAILER

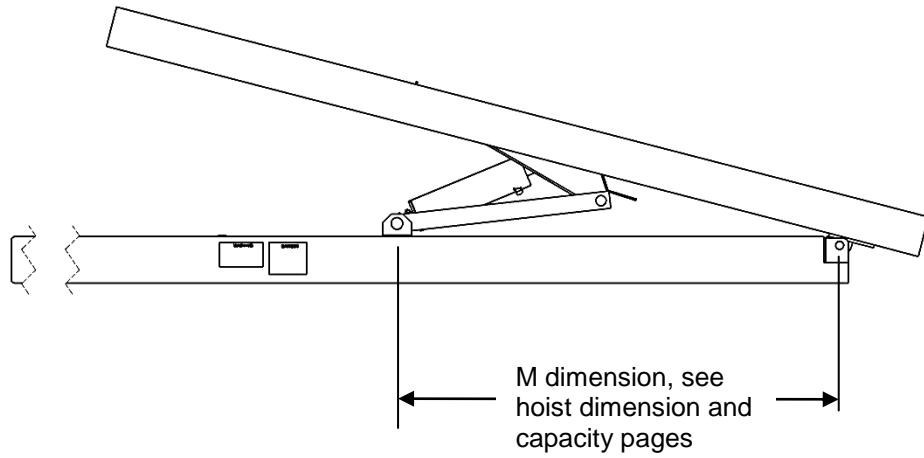

Center hoist assembly on trailer frame

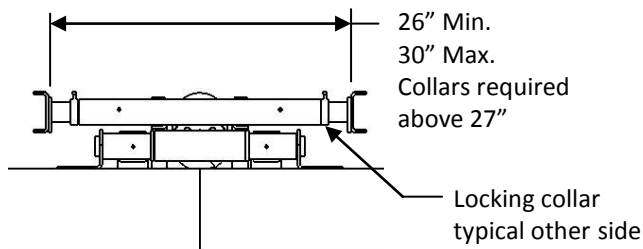
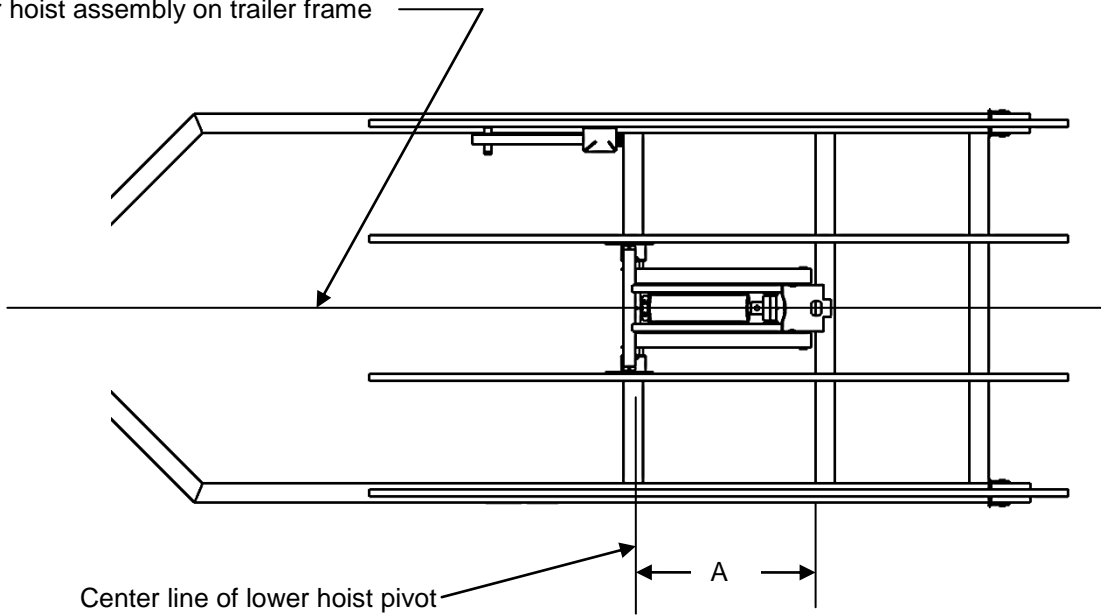

Hoist Model	Dimension A
PH310	27"
PH416	38"
PH516	38"
PH520	46"
PH620	47"
PH625	55"
PH630	63"

## HOIST MOUNTING DIMENSIONS

	"A"	B
PH310	5.25	-----
PH416	6.50	-----
PH516	7.00	-----
PH520	7.00	-----
PH620	7.60	13.00
PH625	7.60	13.00
PH630	7.60	13.00

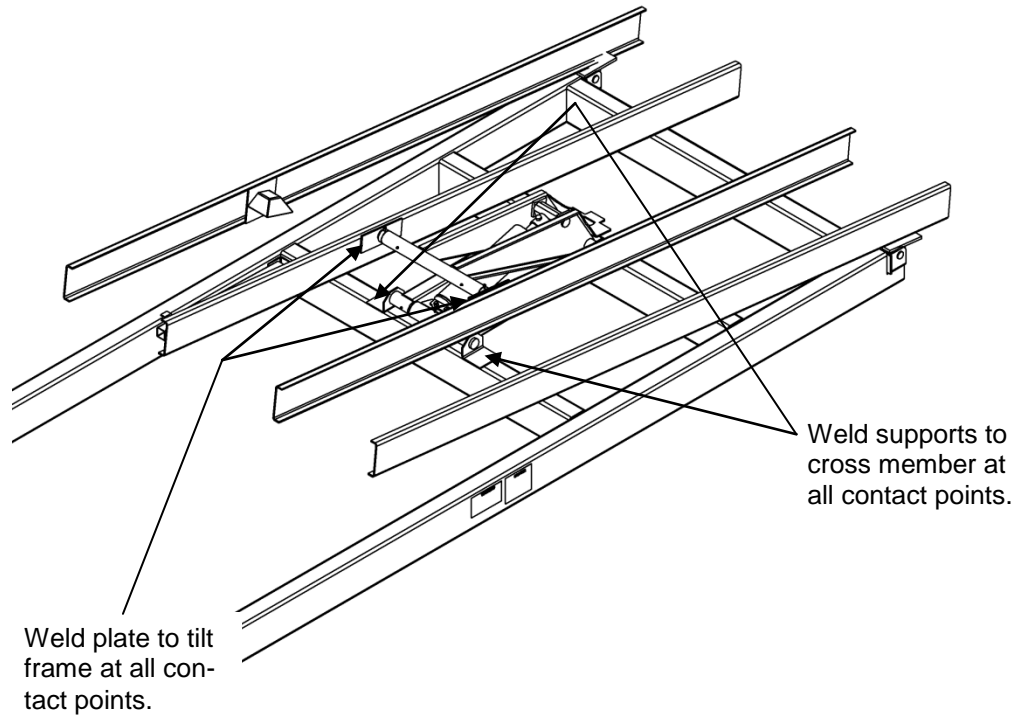
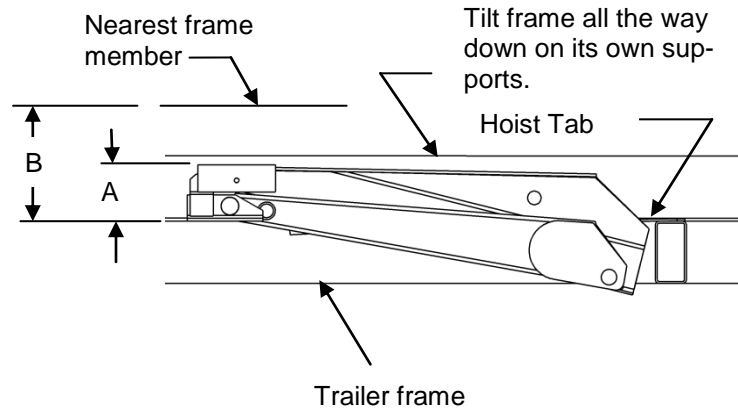

## HOIST AND HINGE GREASE POINTS

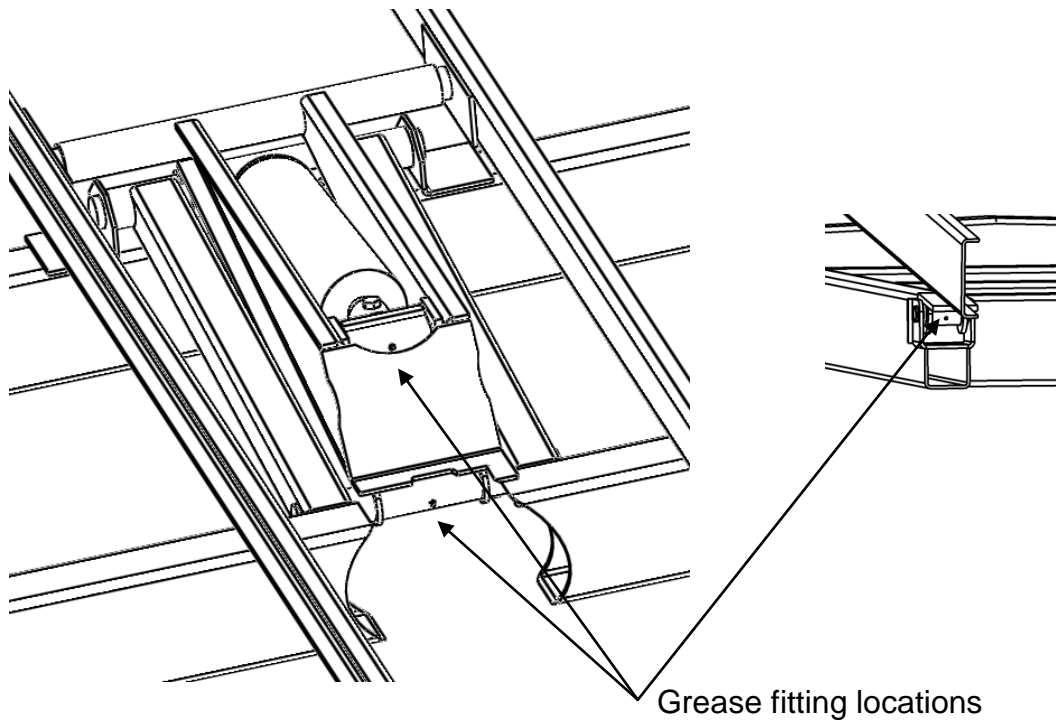
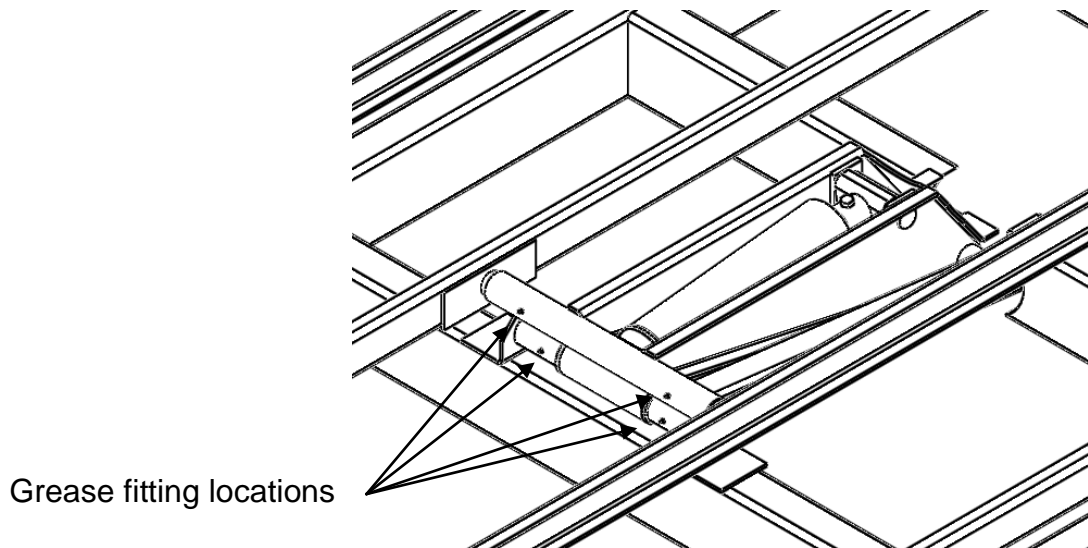



Lubricate the joint with EP3 grease every 6 months.

## DUAL ACTING HYDRAULIC POWER UNIT INSTALLATION

Mount HPU (hydraulic power unit) in a weather tight enclosure on the trailer. See additional instructions supplied with the HPU for mounting, electrical, wireless remote and hydraulic fluid requirements.

All HPU, hoses and fittings between HPU and cylinder are supplied by Premium Supply.

 **CAUTION** If hydraulic components other than those supplied by Premium Supply are used in the hydraulic circuit, it is the purchaser's responsibility to verify that the components are compatible with the components supplied by Premium Supply. Incompatible components may cause failure of the hoist that, in turn, may cause damage to the trailer, vehicle, other property, and may cause injury or death.

 **WARNING** Connecting the hoist to a hydraulic system with more pressure (PSI) or flow (GPM) than is recommended by Premium Supply could cause the hoist to fail during operation. This could lead to damage, serious injury, or death. Be sure you have correct pressure and flow before operation. Consult Premium Supply if you are unsure about your hydraulic system.

 **WARNING** Adjusting the hydraulic pressure to more than the recommended setting could cause the hoist to fail during operation. This could cause damage, serious injury, or death. NEVER adjust the pressure on your own. Consult the trailer manufacturer if the hydraulic pressure is in question. Only qualified personnel should adjust the hydraulic pressure. NEVER adjust the pressure to more than the recommended amount.

### Hydraulic System Pre-Operation

The hydraulic system supplied with the trailer hoist manufactured by Premium Supply consists of components (pump, valves, reservoir, hoses, cylinder, etc.) that are designed to be compatible with each other.

All Premium Supply's trailer hoist liability and warranty will be voided if determined by Premium Supply that substituted hydraulic components were used that were incompatible with those supplied by Premium Supply.

Hoist parameters are listed on the next page. These are listed as a general guide to ensure proper compatibility (when using other hydraulic components). If you have any questions, please contact Premium Supply.

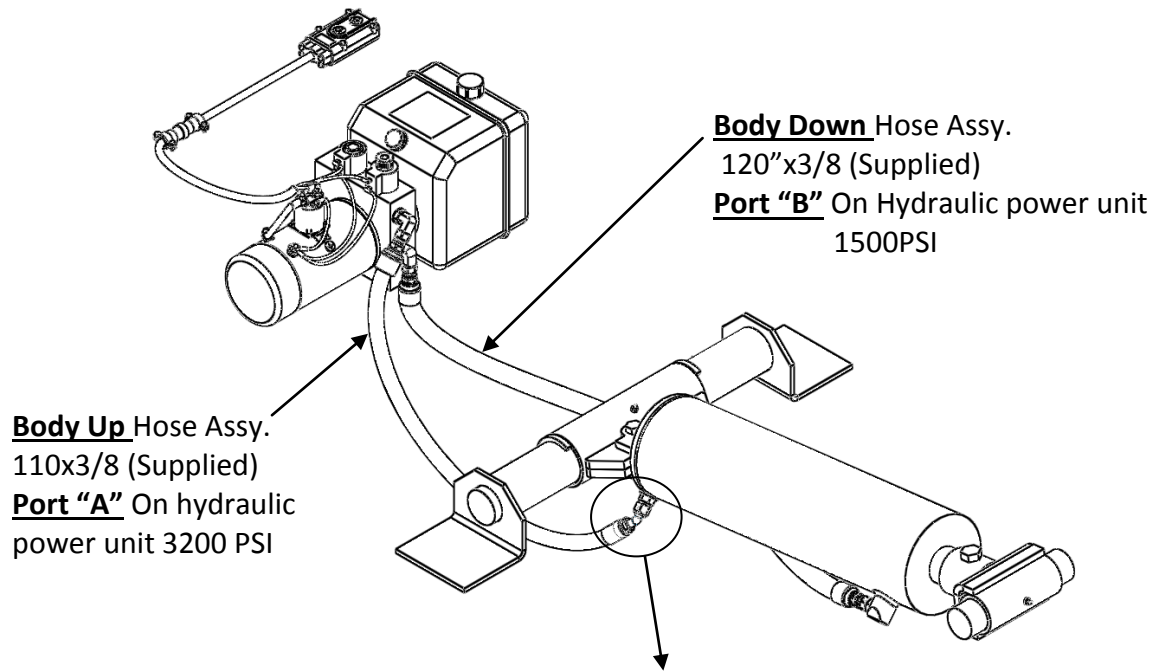

**IMPORTANT:**

Install (supplied) Bridon load control valve at this port of hydraulic cylinder.

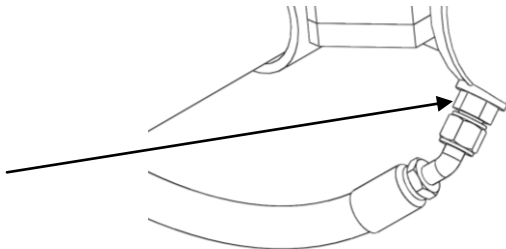



Maximum Hydraulic Flow Rate	2 GPM	Port
Maximum Pressure For "Raising" Portion of Cycle	3200 PSI	A
Maximum Pressure For "Lowering" portion of Cycle	1500 PSI	B

## SINGLE ACTING HYDRAULIC POWER UNIT INSTALLATION

Mount HPU (hydraulic power unit) in a weather tight enclosure on the trailer. See additional instructions supplied with the HPU for mounting, electrical, wireless remote and hydraulic fluid requirements.

All hoses and fittings between HPU and cylinder are supplied by Premium Supply.

 **CAUTION** If hydraulic components other than those supplied by Premium Supply are used in the hydraulic circuit, it is the purchaser's responsibility to verify that the components are compatible with the components supplied by Premium Supply. Incompatible components may cause failure of the hoist that, in turn, may cause damage to the trailer, vehicle, other property, and may cause human injury or death.

 **WARNING** Connecting the hoist to a hydraulic system with more pressure (PSI) or flow (GPM) than is recommended by Premium Supply can cause the hoist to fail during operation. This could lead to damage, serious injury, or death. Be sure you have correct pressure and flow before operation. Consult Premium Supply if you are unsure about your hydraulic system.

 **WARNING** Adjusting the hydraulic pressure to more than the recommended setting may cause the hoist to fail during operation. This could cause damage, serious injury, or death. NEVER adjust the pressure on your own. Consult the trailer manufacturer if the hydraulic pressure is in question. Only qualified personnel should adjust the hydraulic pressure. NEVER adjust the pressure to more than the recommended amount.

### Hydraulic System Pre-Operation

The hydraulic system supplied with the trailer hoist manufactured by Premium Supply consists of components (pump, valves, reservoir, hoses, cylinder, etc.) that are designed to be compatible with each other.

All Premium Supply's trailer hoist liability and warranty will be voided if determined by Premium Supply that substituted hydraulic components were used that were incompatible with those supplied by Premium Supply.

Hoist parameters are listed on the next page. These are listed as a general guide to ensure proper compatibility (when using other hydraulic components). If you have any questions, please contact Premium Supply.



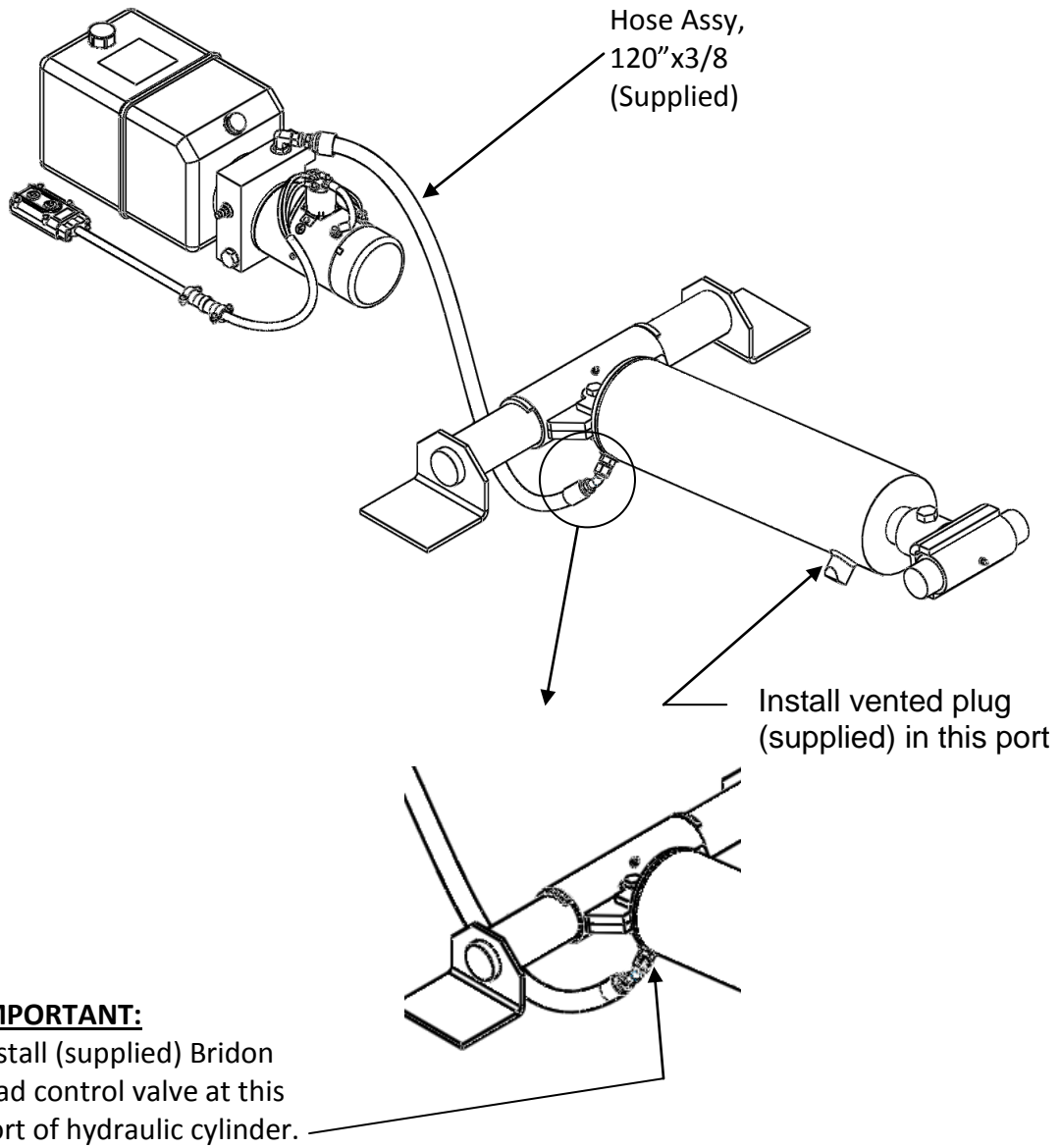

Maximum Hydraulic Flow Rate	2 GPM
Maximum Pressure For "Raising" Portion of Cycle	3200 PSI

## BATTERY HOOKUP DOUBLE ACTING HPU

### **⚠️ WARNING**

Shorting of the electrical system could cause a fire or equipment damage that could lead to injury or death. ALWAYS disconnect the battery prior to installing, servicing, or repairing power unit.

Mount battery in a weather tight enclosure on the trailer. See additional instructions supplied with the HPU for mounting, electrical and hydraulic fluid requirements.

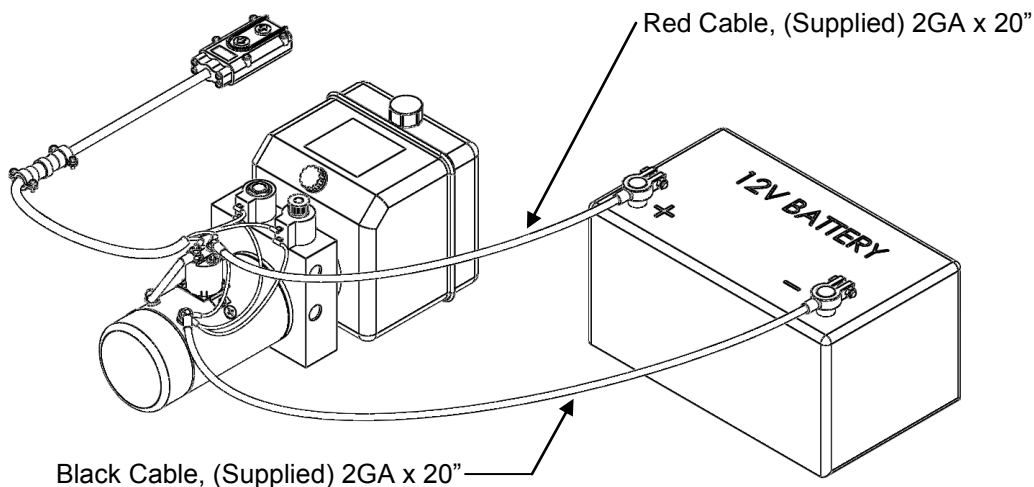

It is highly recommended that the trailer battery be kept charged using one of the Pulsetech products shown on Premium supply website at [www.premium-supply.com](http://www.premium-supply.com)

## BATTERY HOOKUP SINGLE ACTING HPU

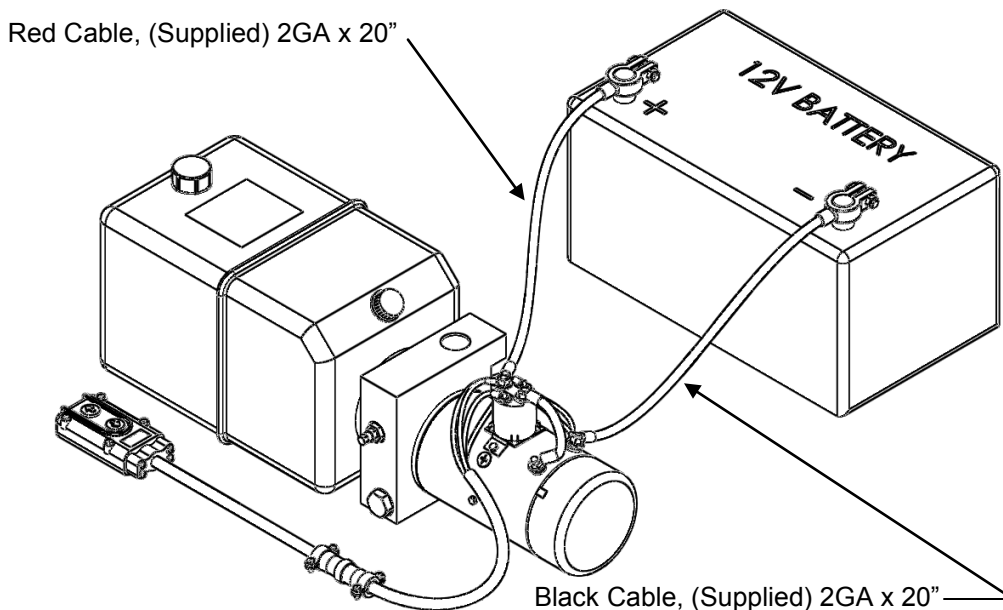

**PARTS INCLUDED IN TRAILER JACK KITS**

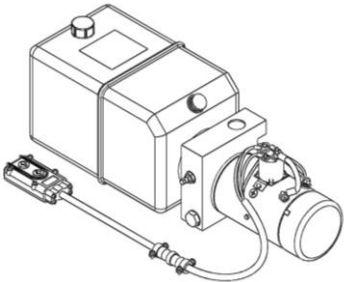
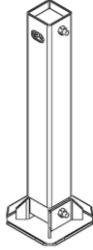
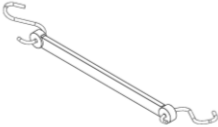
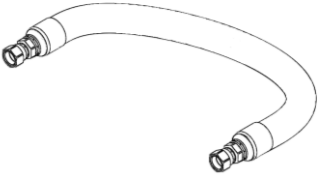
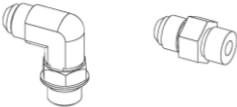
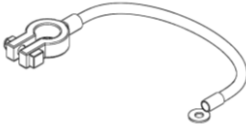
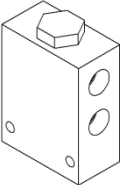
 <p>Hydraulic Power Unit (HPU)</p>	 <p>Trailer Jack</p>
 <p>Rubber Battery Strap</p>	 <p>Hydraulic Hoses Between HPU and Jack</p>
 <p>Hydraulic Fittings</p>	 <p>Battery Cables</p>
 <p>Flow Divider (Dual Jack Kit Only)</p>	

## DUAL HYDRAULIC TRAILER JACK INSTALLATION

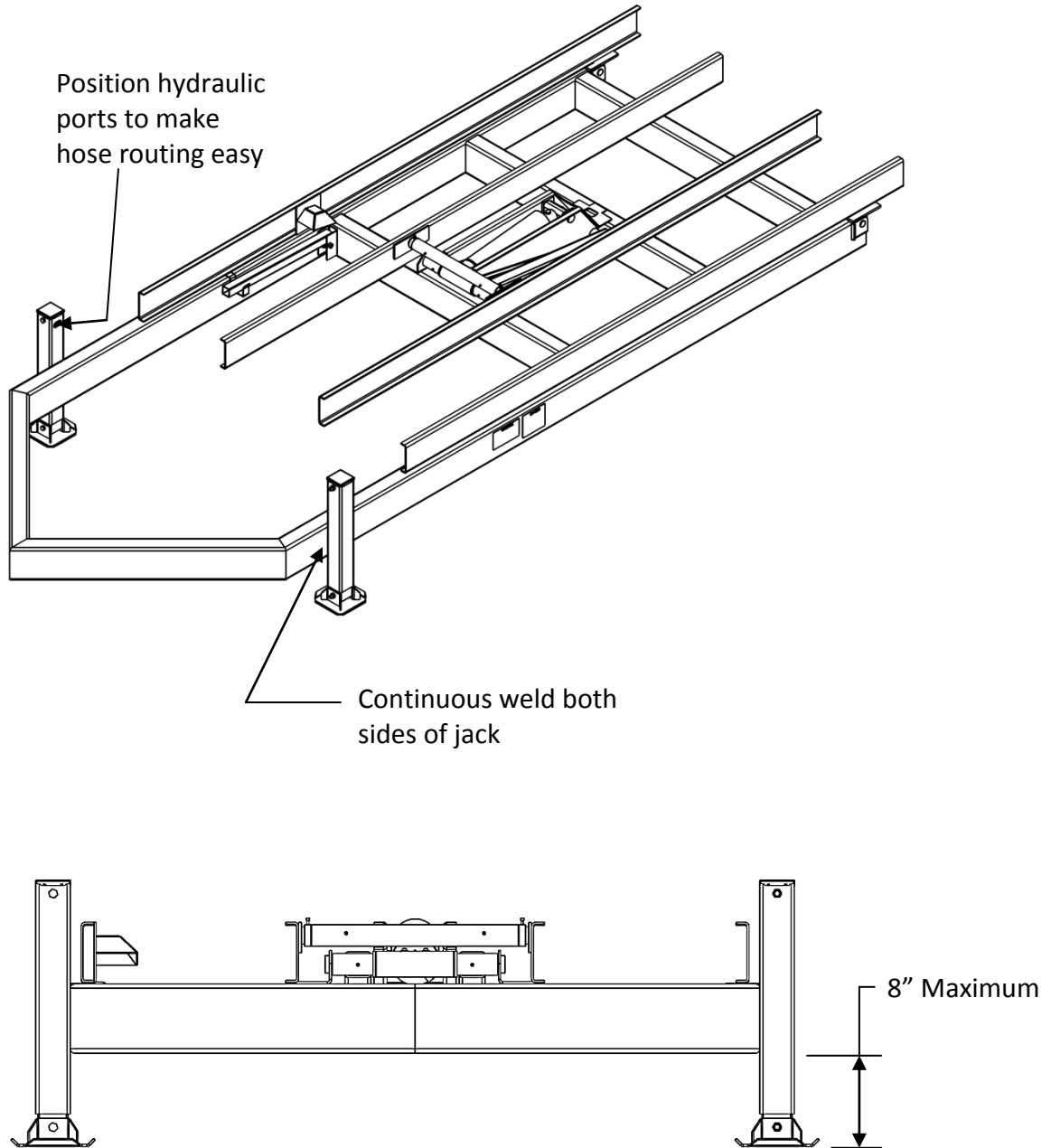

## SINGLE HYDRAULIC TRAILER JACK INSTALLATION

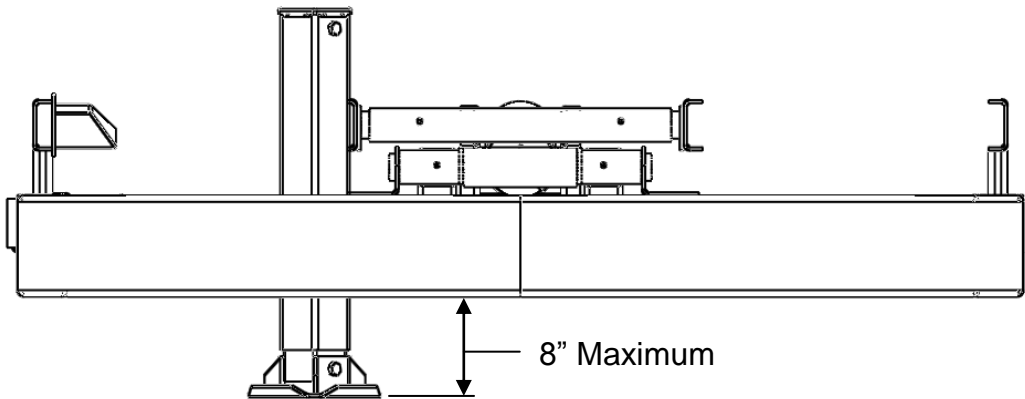
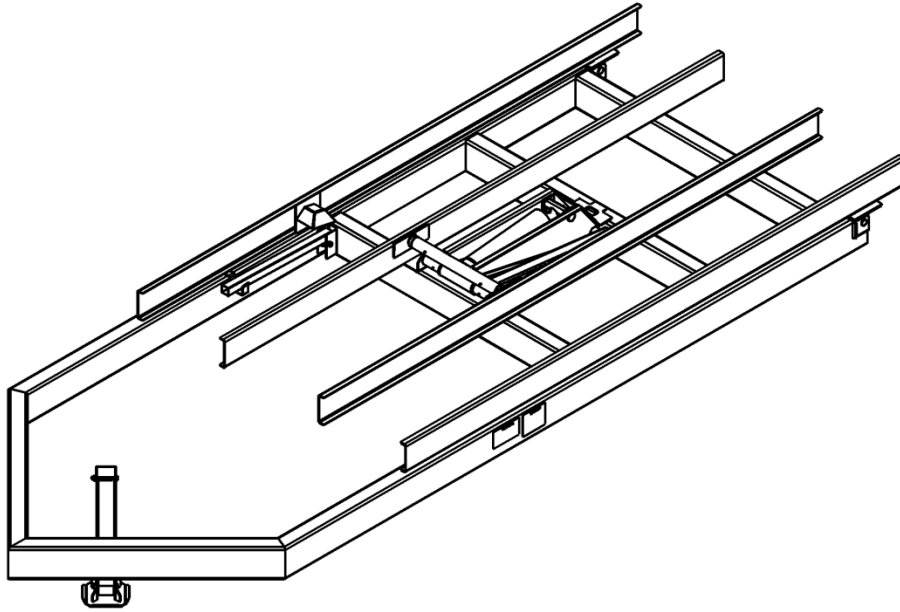

## DUAL DOUBLE ACTING TRAILER JACK AND HOIST HPU CONNECTIONS

See page 18 for electrical wiring

### Dual Trailer Jacks and Hose Connections

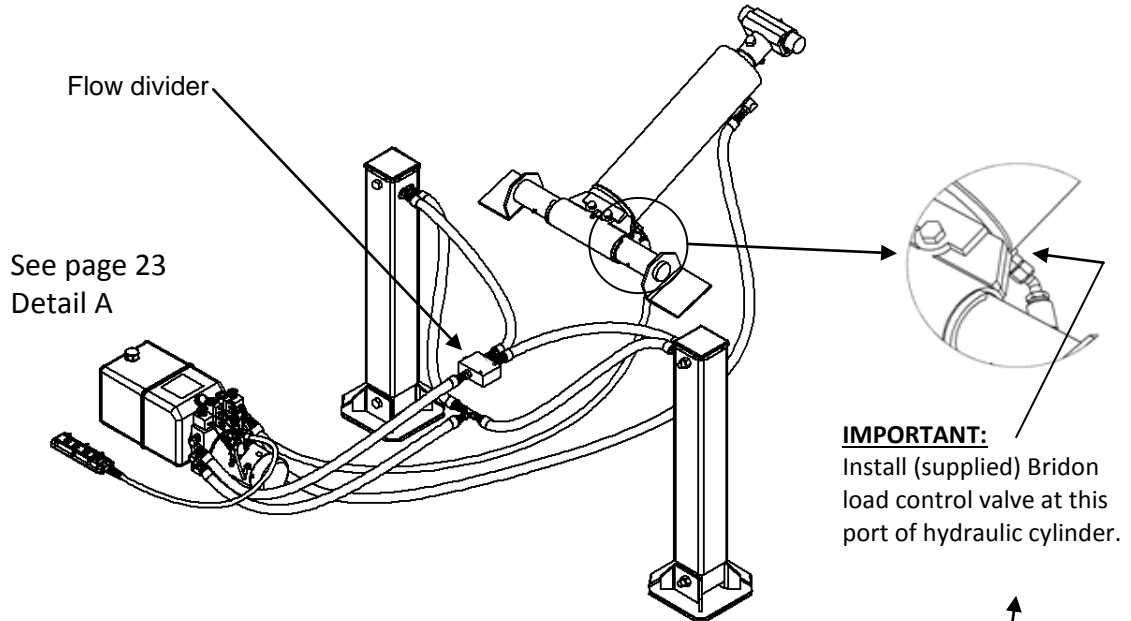

### Single Trailer Jack and Hose Connections

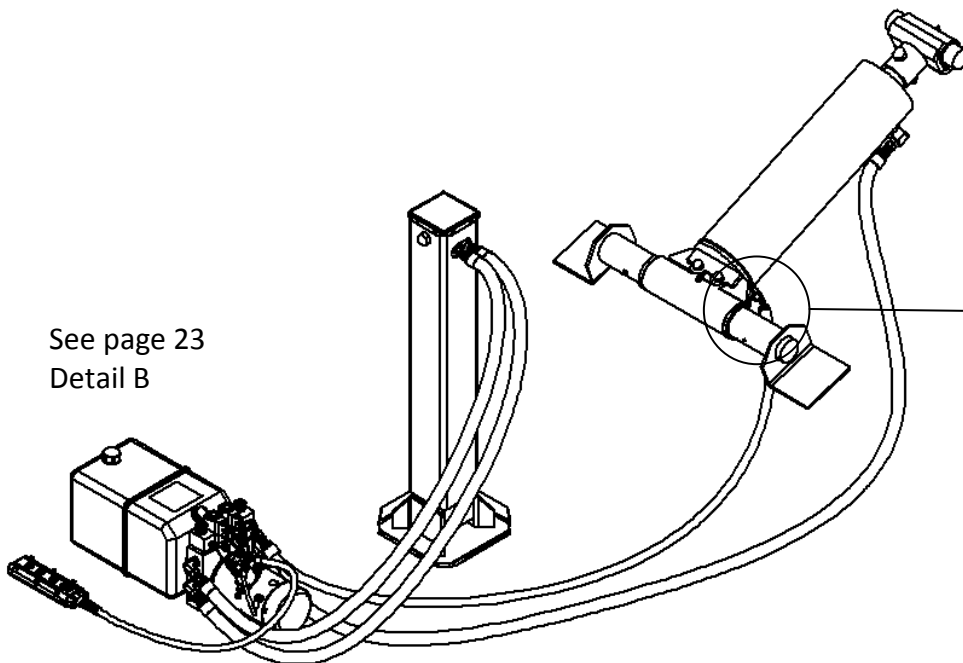

**Trailer Jack Connections  
Detail A**

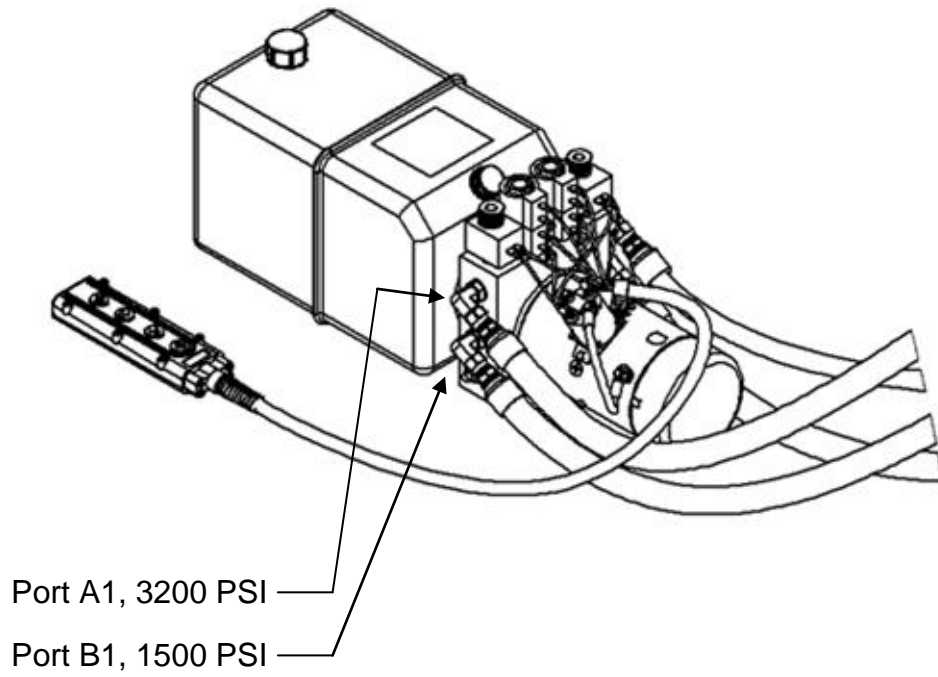

**Hoist Connections  
Detail B**

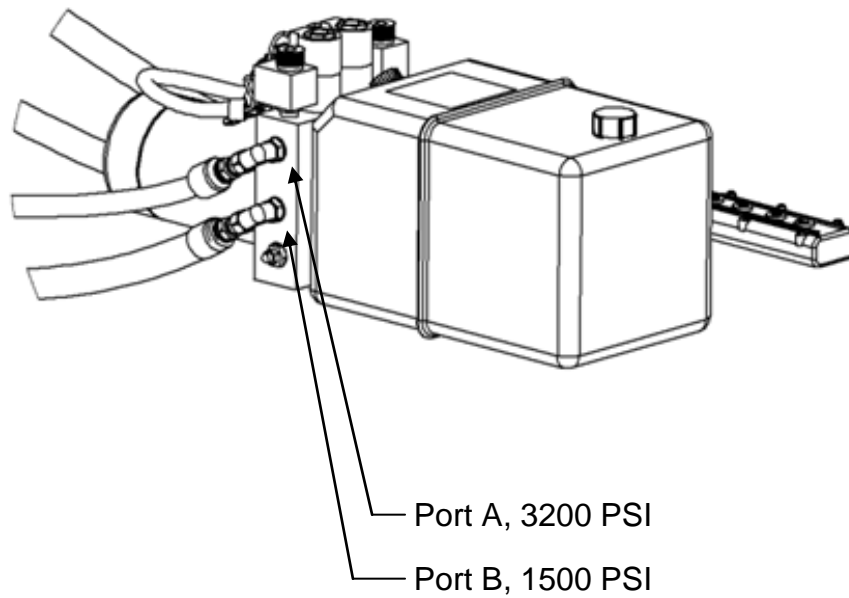

**PH310 HOIST DIMENSIONS AND CAPACITY**

Hoist (with cylinder): 137 lbs.

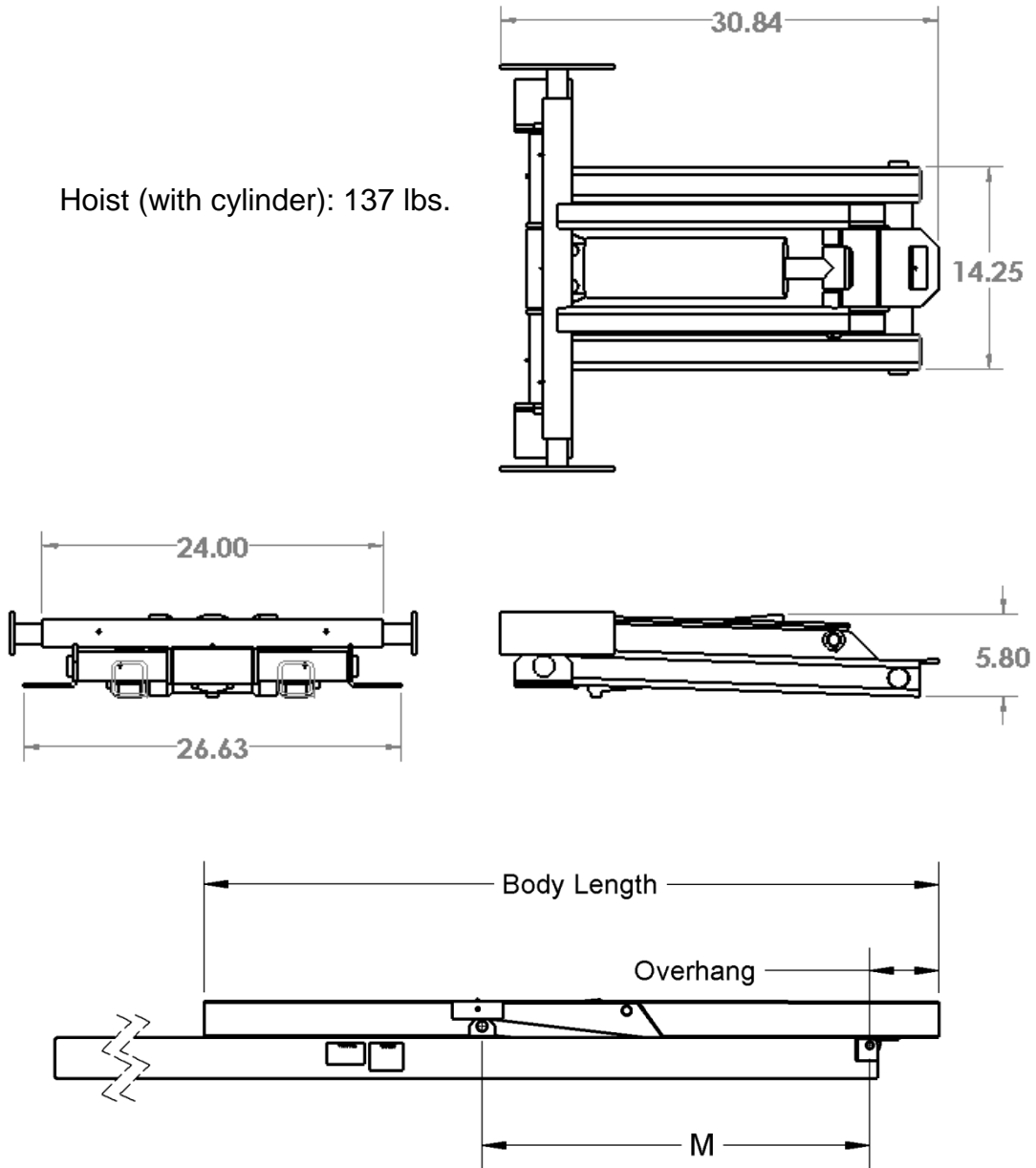

Maximum Dump Angle $\pm 2^\circ$	M
25°	97.00"
30°	80.00"
35°	70.00"
40°	61.00"
45°	55.00"
50°	50.00"



PH-310 Trailer Hoist Conversion Class A  
(Capacity in Tons)

**IMPORTANT:** Because of variations in application, the data contained in these tables is provided as a general guide only.

Body Length "A"	Overhang "B"	Dump Angle 45 Deg	Dump Angle 50 Deg
7'	0"	3.2	2.9
8'	12"	3.8	3.4
9'	12"	3.1	2.9
9'	18"	3.8	3.4
9'	24"	4.5	4.1
10'	18"	3.2	2.9
10'	24"	3.8	3.4
10'	30"	4.5	4.1

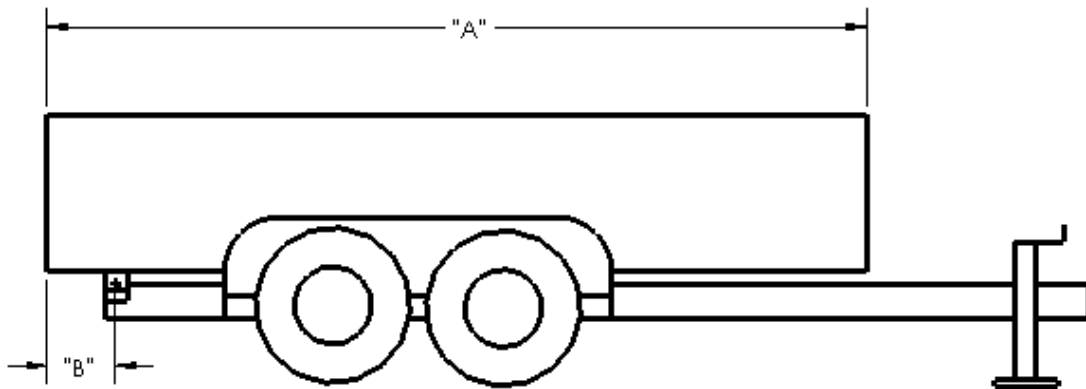

Capacities are based on the following:

1. Water level non-diminishing load.
2. The vertical height between the rear hinge pivot and the floor is no less than 3 inches.
3. The hydraulic relief pressure set at 3,200 psi.

**PH416 HOIST DIMENSIONS AND CAPACITY**

Hoist (with cylinder): 235 lbs.

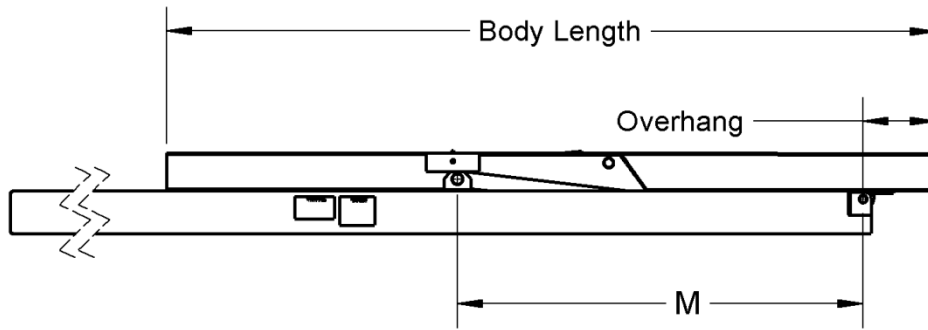
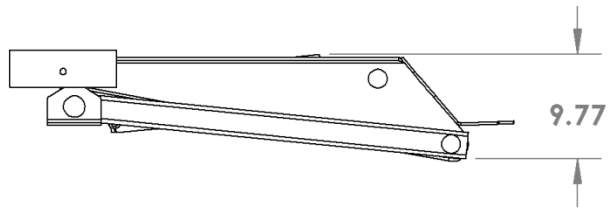
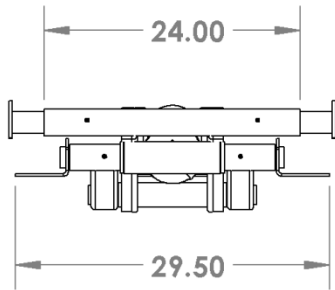
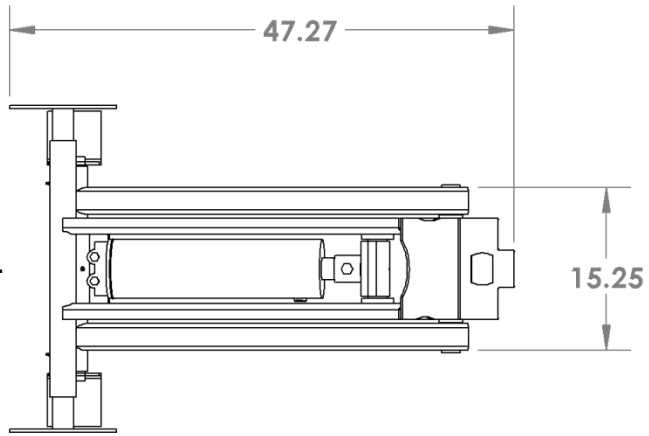

Maximum Dump Angle $\pm 2^\circ$	M
25°	138.00"
30°	116.00"
35°	101.00"
40°	87.00"
45°	79.00"
50°	71.50"

PH-416 Trailer Hoist Dump Class 10, Conversion Class B  
(Capacity in Tons)

**IMPORTANT:** Because of variations in application, the data contained in these tables is provided as a general guide only

Trailer Length "A"	Overhang "B"	Dump Angle 45 Deg	Dump Angle 50 Deg
8'	12"	11.6	10.5
9'	12"	9.9	9.0
9'	18"	11.6	10.5
10'	12"	8.7	7.8
10'	18"	9.9	9.0
12'	12"	6.9	6.3
12'	18"	7.7	7.0
12'	24"	8.7	7.8

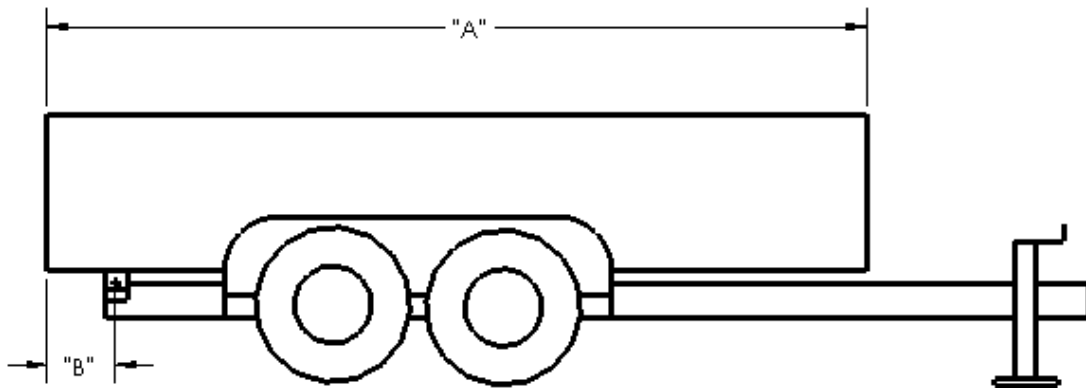

Capacities are based on the following:

1. Water level non-diminishing load.
2. The vertical height between the rear hinge pivot and the floor is no less than 3 inches.
3. The hydraulic relief pressure set at 3,200 psi.

### PH516 HOIST DIMENSIONS AND CAPACITY

Hoist (with cylinder): 276 lbs.

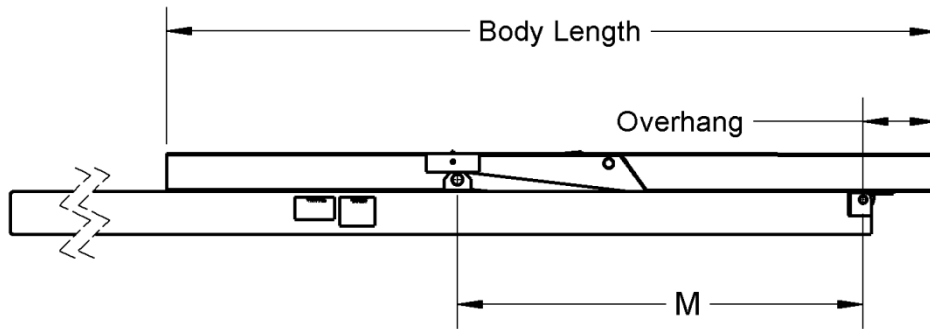
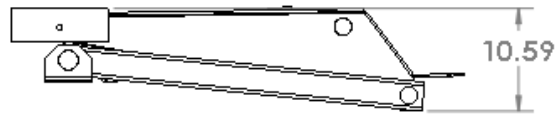
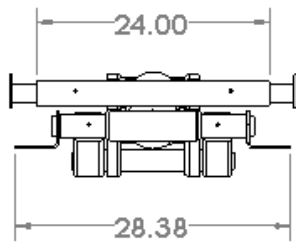
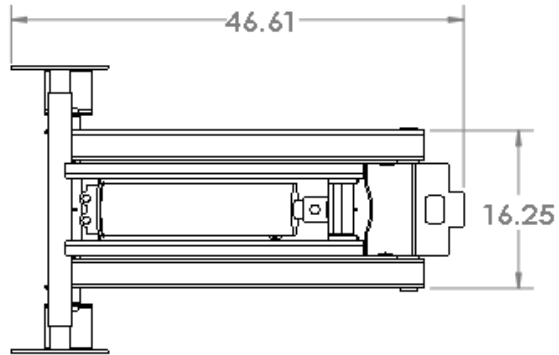

Maximum Dump Angle $\pm 2^\circ$	M
25°	135.00"
30°	113.00"
35°	97.00"
40°	85.00"
45°	76.00"
50°	67.50"

PH-516 Trailer Hoist, Dump Class 20, Conversion Class C  
(Capacity in Tons)

**IMPORTANT:** Because of variations in application, the data contained in these tables is provided as a general guide only.

Trailer Length	Overhang	45 Deg	50 Deg
10'	12"	9.6	8.7
10'	18"	11.0	9.9
10'	24"	12.8	11.6
12'	12"	7.6	6.9
12'	18"	8.5	7.7
12'	24"	9.6	8.7
14'	12"	6.4	5.8
14'	18"	6.9	6.3
14'	24"	7.6	6.9

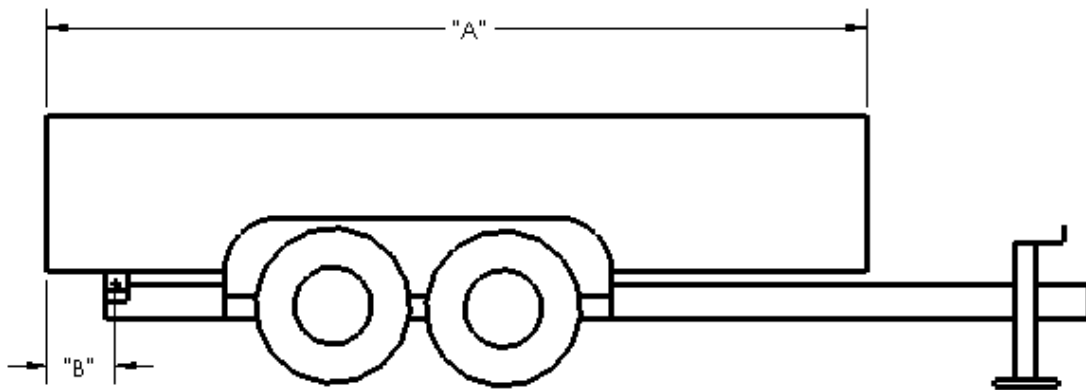

Capacities are based on the following:

1. Water level non-diminishing load.
2. The vertical height between the rear hinge pivot and the floor is no less than 3 inches.
3. The hydraulic relief pressure set at 3,200 psi.

### PH520 HOIST DIMENSIONS AND CAPACITY

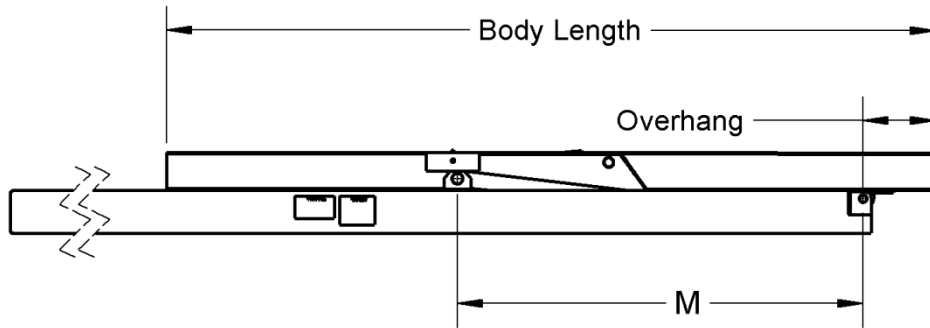
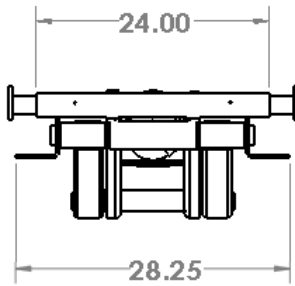
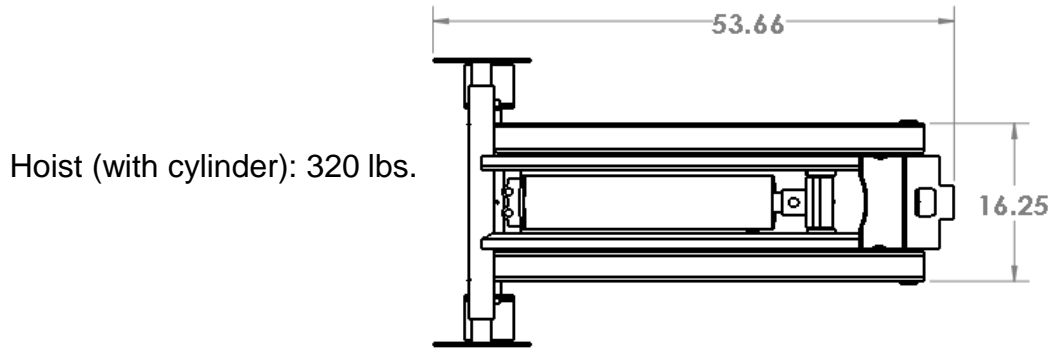

Maximum Dump Angle $\pm 2^\circ$	M
25°	170.00"
30°	142.00"
35°	125.00"
40°	109.00"
45°	96.75"
50°	87.75"

PH-520 Trailer Hoist, Dump Class 40, Conversion Class D  
(Capacity in Tons)

**IMPORTANT:** Because of variations in application, the data contained in these tables is provided as a general guide only.

Body Length "A"	Overhang "B"	Dump Angle 45 Deg	Dump Angle 50 Deg
10'	12"	12.5	11.3
10'	18"	14.3	12.9
10'	24"	16.5	15.1
12'	12"	9.9	9.0
12'	18"	11.2	10.1
12'	24"	12.5	11.3
14'	12"	8.3	7.5
14'	18"	9	8.1
16'	12"	7.1	6.4
16'	18"	7.7	6.9

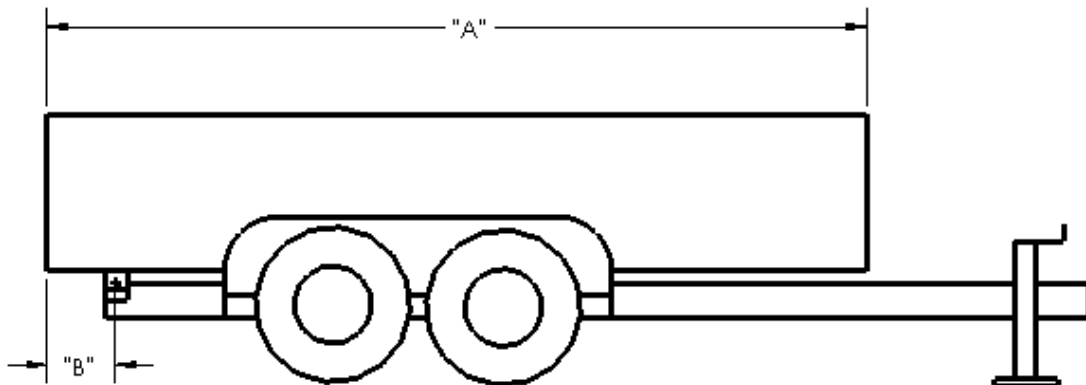

Capacities are based on the following:

1. Water level non-diminishing load.
2. The vertical height between the rear hinge pivot and the floor is no less than 3 inches.
3. The hydraulic relief pressure set at 3,200 psi.

### PH620 HOIST DIMENSIONS AND CAPACITY

Hoist (with cylinder): 512 lbs.

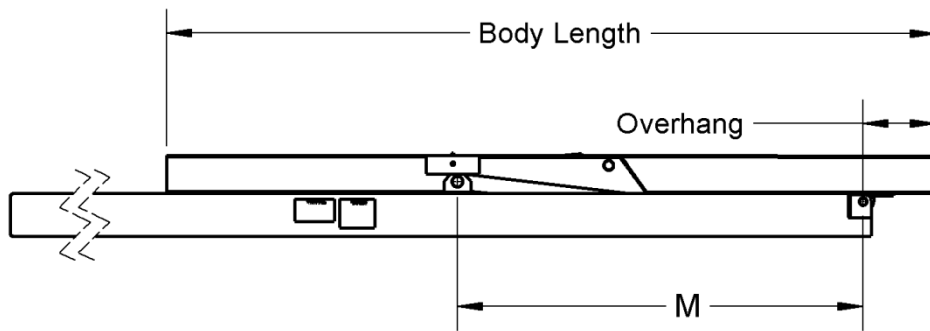
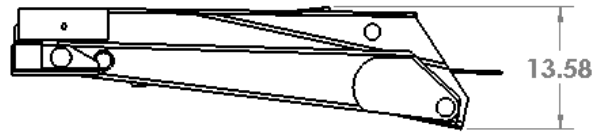
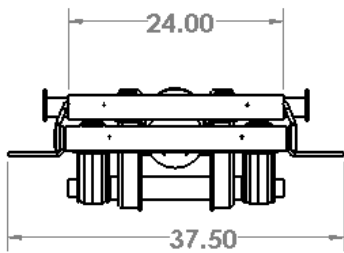
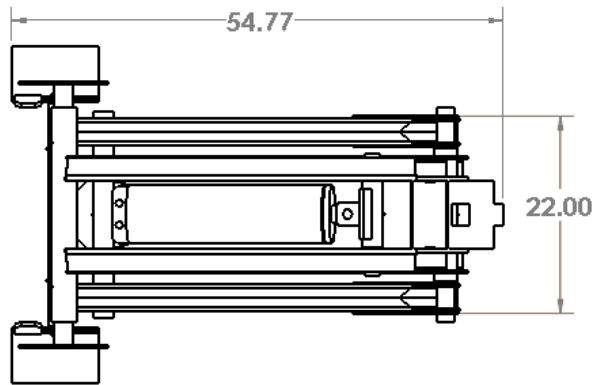

Maximum Dump Angle	M
22.5°	174.25"
25°	157.5"
30°	130.00"
35°	113.25"
40°	100.00"
45°	90.25"
50°	81.75"



PH-620 Trailer Hoist, Dump Class 50, Conversion Class E  
(Capacity in Tons)

**IMPORTANT:** Because of variations in application, the data contained in these tables is provided as a general guide only

Body Length "A"	Overhang "B"	Dump Angle 45 Deg	Dump Angle 50 Deg
14'	12"	11.0	10.0
14'	18"	12.0	10.9
14'	24"	13.3	12.0
16'	12"	9.5	8.6
16'	18"	10.2	9.2
16'	24"	11.0	10.0
18'	18"	8.8	8.0
18'	24"	9.5	8.6

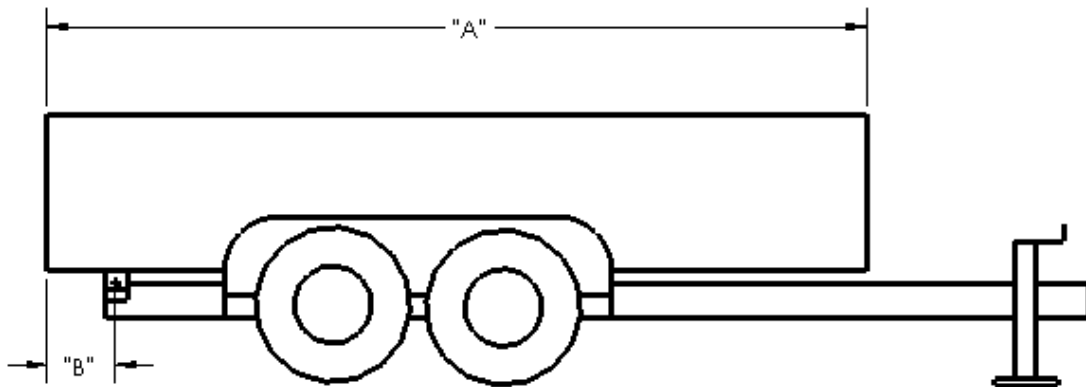

Capacities are based on the following:

1. Water level non-diminishing load.
2. The vertical height between the rear hinge pivot and the floor is no less than 3 inches.
3. The hydraulic relief pressure set at 3,200 psi.

### PH625 HOIST DIMENSIONS AND CAPACITY

Hoist (with cylinder): 622 lbs.

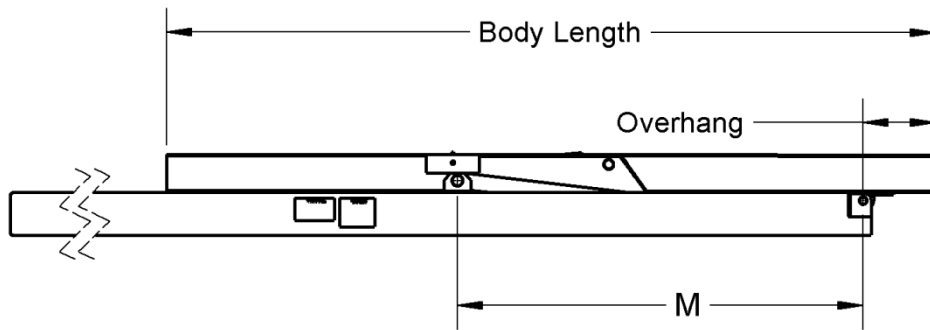
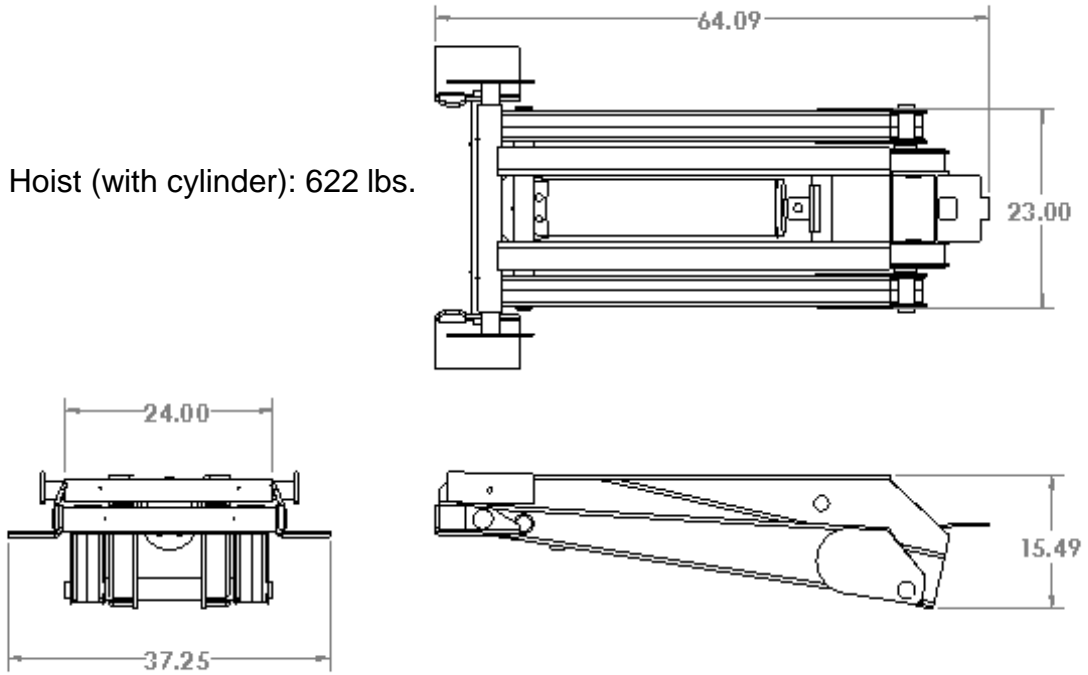

Maximum Dump Angle $\pm 2^\circ$	M
25°	180.00"
30°	150.00"
35°	131.00"
40°	115.00"
45°	104.00"
50°	95.00"

PH-625 Trailer Hoist, Dump Class 50, Conversion Class E  
(Capacity in Tons)

**IMPORTANT:** Because of variations in application, the data contained in these tables is provided as a general guide only

Body Length "A"	Overhang "B"	Dump Angle 45 Deg	Dump Angle 50 Deg
16'	12"	11.8	10.7
16'	18"	12.7	11.6
16'	24"	13.7	12.5
18'	18"	11.0	10.7
18'	24"	11.8	11.9
20'	18"	9.7	8.8
20'	24"	10.3	9.4

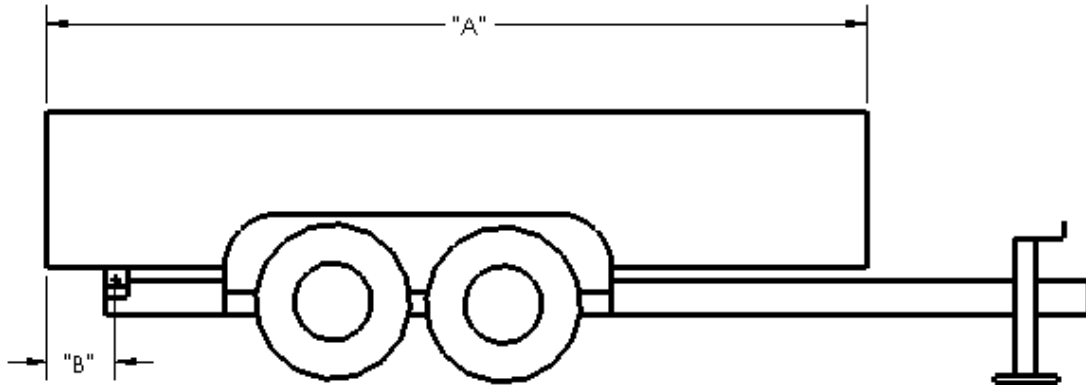

Capacities are based on the following:

1. Water level non-diminishing load.
2. The vertical height between the rear hinge pivot and the floor is no less than 3 inches.
3. The hydraulic relief pressure set at 3,200 psi.

### PH630 HOIST DIMENSIONS AND CAPACITY

Hoist (with cylinder): 659 lbs.

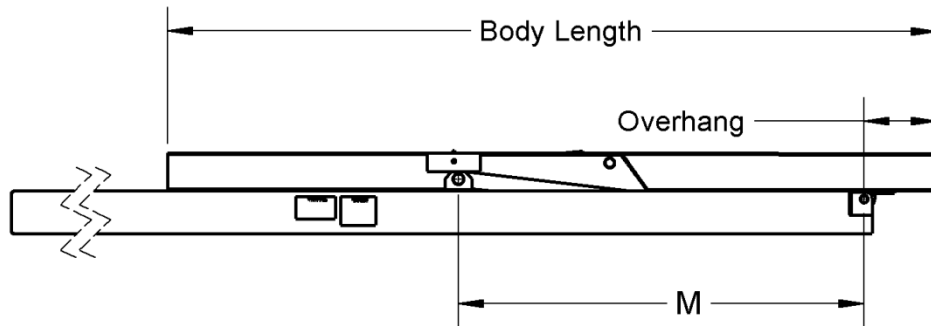
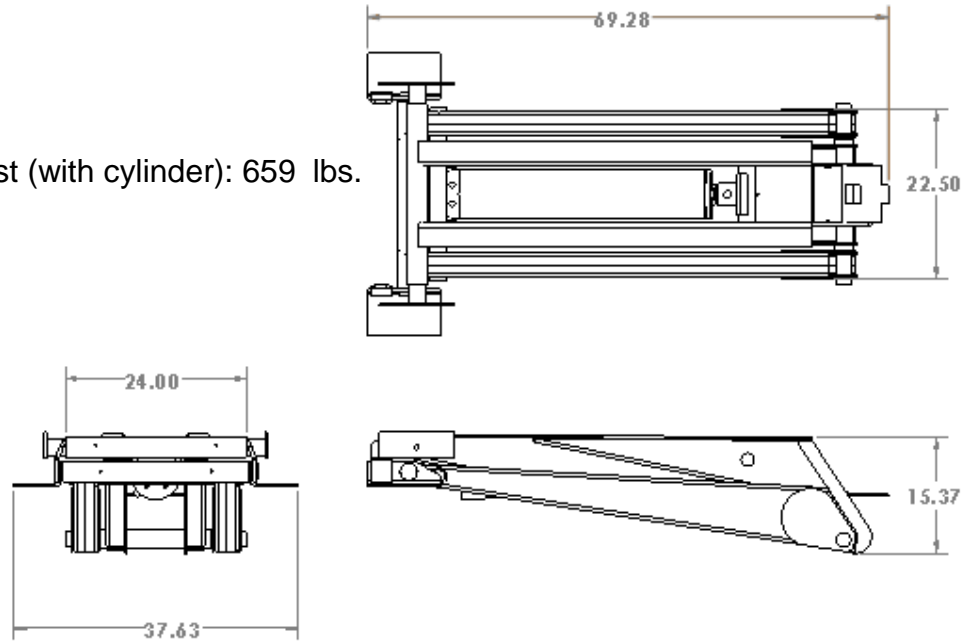

Maximum Dump Angle $\pm 2^\circ$	M
25°	239.00"
30°	195.00"
35°	170.00"
40°	150.00"
45°	135.00"
50°	123.00"

PH-630 Trailer Hoist, Dump Class 60, Conversion Class F

(Capacity in Tons)

IMPORTANT: Because of variations in application, the data contained in these tables is provided as a general guide only.

Body Length "A"	Overhang "B"	Dump Angle 45 Deg	Dump Angle 50 Deg
16'	12"	13.8	12.6
16'	18"	14.9	13.6
16'	24"	16.1	14.7
18'	18"	12.9	11.8
18'	24"	13.8	12.6
20'	30"	12.9	11.8

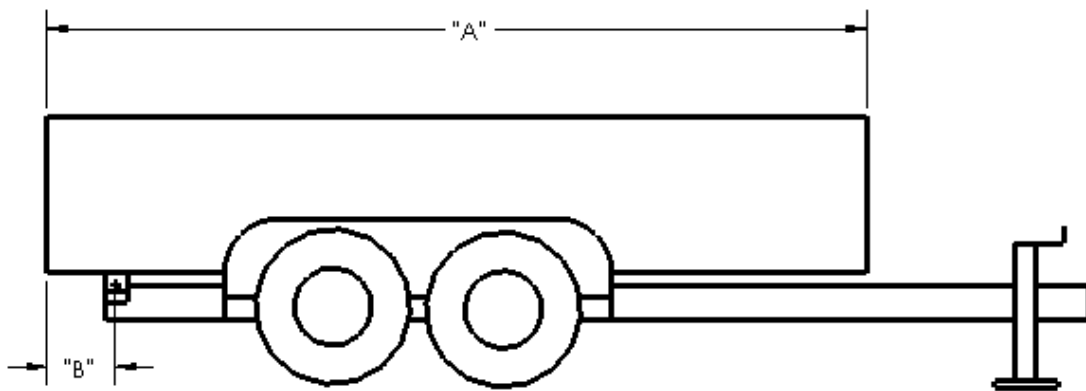

Capacities are based on the following:

1. Water level non-diminishing load.
2. The vertical height between the rear hinge pivot and the floor is no less than 3 inches.
3. The hydraulic relief pressure set at 3,200 psi.

### HOIST FULLY OPEN DIMENSIONS

